

# 1 1/2" NAIL-LINE PANEL

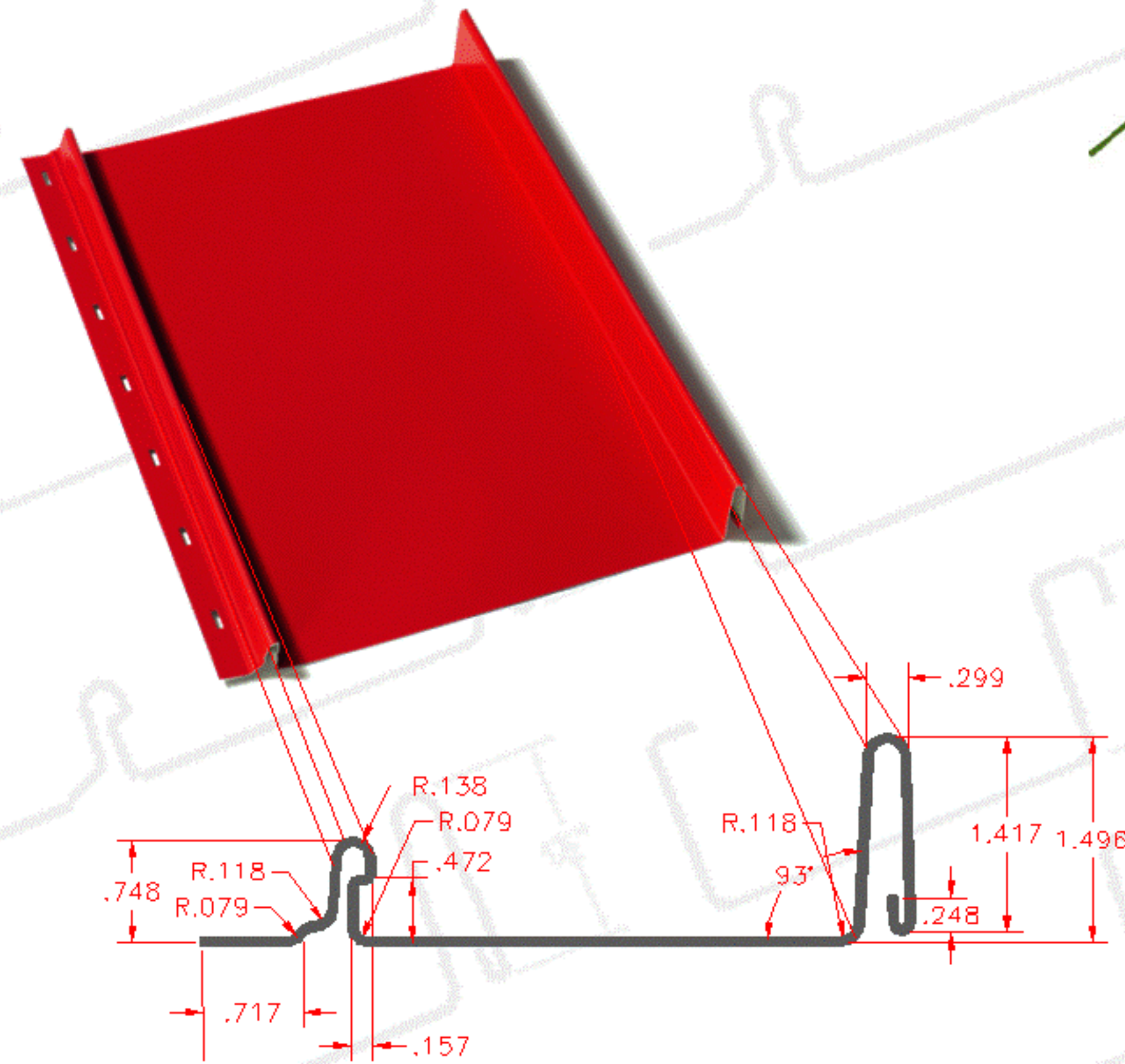

Hilliard, Ohio  
 PH: 614-876-4280 / FX: 614-771-7625  
 www.metalformedgoods.com



## Advantages

- ◆ Clip-less design reduces costs and installation time
- ◆ Nominal 1 1/2" seam height with hidden fasteners
- ◆ Available widths from 11" to 19"
- ◆ Integral locking seams do not require mechanical seaming
- ◆ Slotted nail strip allows for thermal expansion
- ◆ 30 Year Finish Warranty
- ◆ 24 Gauge Kynar steel standard

## Materials:

24 gauge galvanized / galvalume steel (Standard)  
 22 & 26 gauge galvanized / galvalume steel  
 .032 Aluminum (Kynar or Anodized)  
 16 & 20 ounce copper

## Performance:

ASTM 1592 Wind Uplift  
 ASTM 1680 Air Infiltration  
 ASTM 1646 Water Penetration

LOAD SPAN TABLE			
1 1/2" Nail Line - 12" Width x 24 Gauge			
SPAN (FT)	THREE EQUAL SPANS		
	W (PSF)	RE	RI
2	38.41	30.7	84.5
2.5	30.73	30.7	84.5
3	30.09	36.1	99.3
3.5	25.79	36.1	99.3
4	22.57	36.1	99.3

W = Allowable Uniform Load

RE = End Support Reaction (#/ft)

RI = Intermediate Support Reaction (#/ft)

